

# Turbo Chain: A New Recovery System Beyond Ethernet Redundant Ring Technology

Sean Wang, Product Manager

## Overview

*This white paper will explore the various challenges presented by existing redundant networking technologies and introduce a new redundant solution that resolves many existing problems.*

In recent years, redundant Ethernet technology has been rapidly and popularly adopted in the industrial automation field due to its enhanced reliability. However as a redundant network becomes more heavily utilized, its networking requirements consequently grow more demanding, making some of the redundant technologies (such as simple ring topology) inefficient in certain situations. This problem has presented redundant technology with a functional challenge because an ideal redundant Ethernet solution should be capable of supporting multiple redundant connections. In this white paper, we'll first introduce the standard redundant technologies. Next, we'll unveil a new breakthrough redundant technology that can be applied to increase the efficiency and availability of multiple redundant connections in industrial applications, followed by some scenarios to describe the benefits of adopting new redundant solutions.

Released on October 5, 2009

**Copyright © 2009 Moxa Inc., all rights reserved.**

## Moxa Turbo Chain

### Building High-availability Redundant Networks

*Ease of deployment, high availability, rapid failure recovery, and future expandability are important features for industrial redundant Ethernet networks.*

For industrial Ethernet redundant networks, one of the most common problems encountered today is the lack of a technology to easily build high-availability networks containing complex redundant connections. Nonetheless, this requirement is still highly needed in various industrial fields (e.g., wind power, oil pipelines, and railway automation networks). In these applications, large Ethernet networks with network redundancy are often required, and the network may encompass multiple locations over substantial distances and require more flexible topologies.

In addition to the above, other problems such as troublesome network expansions or slow failure-recovery are also frequently encountered. As we go over the advantages and disadvantages of the standard redundant technologies, we'll discuss how Moxa's latest technology, Turbo Chain, can address these issues precisely and efficiently.

### Network Redundancy Technologies

There are many existing mechanisms that can enhance fault-tolerance in an Ethernet network. The most common of these are Mesh networking, STP, RSTP, and proprietary ring redundancy.

*Mesh networking is reliable and robust, but has very high cost due in large part to the cabling requirements.*

#### ● Mesh Networking

A mesh network is a network where all the nodes are connected to each other in a complete network. Every node is connected to other nodes on the network through hops. Some are connected through a single hop and some may be connected with more than one hop. Data traveling on the mesh network is automatically configured to reach the destination by taking the shortest route. Mesh networking is reliable and is self-repairing. If one node fails, the network finds an alternate route to transfer the data. In a mesh network, it is highly unlikely that all the nodes in a single network will break down at any given point of time. Although mesh networking is highly

## Moxa Turbo Chain

reliable and robust for data transmission, it has a higher communications overhead and there are increased costs from the cables required to connect all the nodes to each other.

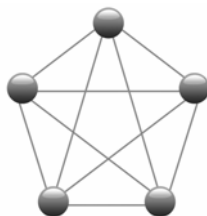

Figure 1: Mesh Networking

*STP has reduced cabling requirements compared to a mesh network, but its recovery time is slow and unsuitable for industrial applications.*

- **Spanning Tree Protocol (STP)**

Spanning Tree Protocol as defined in the IEEE 802.1D standard is designed to eliminate loops in a network by cutting the network into a loop-free tree shape. It helps a network achieve link redundancy and path optimization. The network shown in Figure 2 is an example of a redundant Ethernet network that uses STP and includes a loop between switches 1 to 5. STP uses an algorithm to find redundant links in a network and allow certain paths as backup paths to prevent looping. When STP is running, packets sent from switch 5 to the root switch will go through switch 3. When switch 3 disconnects or fails, STP then automatically re-arranges the connections by activating the backup paths to forward data.

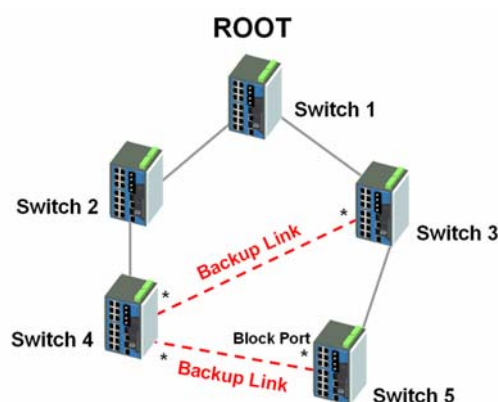

Figure 2: Spanning Tree Protocol blocks redundant ports to resolve loops

## Moxa Turbo Chain

Although STP resolves looping and achieves network redundancy, it has some drawbacks. One of these is slow recovery time; with STP, recovery usually takes 15 seconds after the spanning tree is established. This recovery time is too long for industrial applications.

*RTSP improves somewhat on STP's slow recovery time, but remains unsuitable for many mission critical applications.*

- **Rapid Spanning Tree Protocol (RSTP)**

To overcome the slow convergence of STP, the IEEE released the IEEE 802.1w standard to make improvements based on STP. This shortened the recovery speed to 1 second. However, for some real-time and mission critical industrial applications, such as military and process control systems, recovery time must be under 100 milliseconds to ensure the reliability of the network.

STP & RSTP are open standards that many Ethernet switch manufacturers have implemented in their managed switch products. The faster self-healing time of RSTP is very helpful in an enterprise network where a few seconds of network delay is acceptable. However in an industrial control network, one second of missed communications can cause serious problems. Factory automation applications typically involve machinery requiring much shorter fail over times. This is required for safe operation of the processes being controlled and to prevent expensive system downtime.

*Ring redundancy is a cost-effective solution with excellent recovery times, but has limitations in interoperability and expandability.*

- **Proprietary Ring Redundancy**

Ring redundancy is common among today's industrial Ethernet networks. It is a more cost-effective solution than a mesh network, and overcomes the recovery time problem of STP/RSTP. There are many different ring redundancy technologies featuring a guaranteed recovery time of a few milliseconds offered by industrial Ethernet solution providers, such as Moxa's Turbo Ring. Ring redundancy ensures non-stop operation of networks with an extremely fast recovery time. For example, using Turbo Ring, if any segment of the network is disconnected, the network system will recover in less than 20 ms by activating the backup path in a ring. But there are still

## Moxa Turbo Chain

some drawbacks to ring redundancy. Interoperability is a challenge because redundant ring technologies are proprietary to individual suppliers. In addition, ring redundancy only supports limited rings in a single switch.



Figure 3: Example of ring redundancy

### Turbo Chain: A New Recovery System Beyond Redundant Ring

*Moxa's Turbo Chain improves on existing ring technology and is robust and easy to install.*

Moxa's Turbo Chain is an advanced redundancy technology that solves the inflexible topologies of mesh networking, the slow recovery time of STP/RSTP, and the limited interoperability or restricted rings of ring redundancy.

Using the innovative "chain" concept, network administrators can flexibly create any type of redundant topology among any network segment. Turbo Chain works by connecting several Ethernet switches together to form a daisy-chain, where a Head-Switch and a Tail-Switch (the edge switches at the two sides of the chain) are configured first, then the remaining switches are configured as member switches. Next, simply link the 2 ends of the chain to an Ethernet network, and then the setup is done. A brief illustration is shown on Figure 4.

## Moxa Turbo Chain

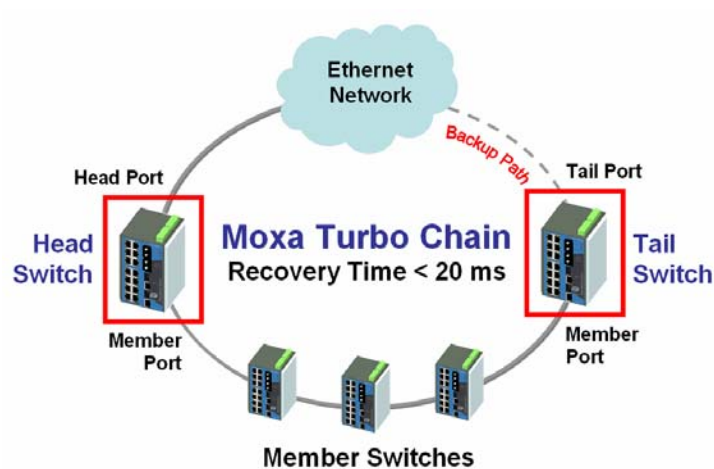

Figure 4: Turbo Chain Networking

Turbo Chain provides the prompt redundancies required for industrial applications. Once a chain-segment fails, the blocked path (link between the tail-switch and the outside network) will rapidly be activated within 20 milliseconds. This fast recovery-mechanism will ensure that the industrial Ethernet network remains available almost constantly.

### Turbo Chain Benefits

*Turbo Chain features the advantages of older redundant technologies, is cost effective, rapidly self-healing, highly expandable, and completely interoperable with existing networks.*

Turbo Chain presents significant advantages for industrial networks that require complex redundant topologies, and enables the highest reliability and availability of industrial Ethernet network applications. Whenever a network is adopting a multiple-ring architecture, Turbo Chain is the best solution for the following four reasons: flexible/scalable construction, unrestricted expansion, fast fault recovery, and cost-effective deployment.

- **Build Highly Flexible and Scalable Redundant Topologies**

Turbo Chain features extreme flexibility in accommodating any type of complex network topology. With the chain methodology, network engineers now have the freedom to create as many redundant connections as they have switches and ports by simply linking a new Turbo Chain to any segment of the Ethernet Network.

## Moxa Turbo Chain

- **Unrestricted Expansion to Form Scalable Redundant Networks**

Turbo Chain allows unlimited and easy network expansions. Network engineers are not required to reconfigure the existing network, but rather, use Turbo Chain to scale up the redundant networks directly. In addition, Turbo Chain can be connected to a network using any other redundant technology, such as STP, RSTP, and Moxa's Turbo Ring technology.

- **Reliable and Immediate Fault Recovery Mechanism**

Turbo Chain offers industrial-grade redundancy that is capable of tolerating network-segment failures. If any given network link fails, Turbo Chain will instantly activate the blocked path, and continue to forward the data immediately—all with a recovery time of less than 20 milliseconds.

- **Lower Deployment Cost Versus Ring Coupling**

Turbo Chain reduces deployment time, effort, and installation costs, since the connection of different redundant networks can be achieved directly with no ring coupling needed. When compared with ring-coupling technology, Turbo Chain presents significant cost reductions, since Ethernet ports or kilometers of fiber-cablings that form ring coupling paths can be saved. This type of deployment is ideal for applications that require network redundancy and have budget considerations and cabling difficulties with coupling.

### Case Studies

*Because of its many advantages over older technologies, Moxa's new Turbo Chain technology is the optimal solution for many industrial applications.*

Industrial applications use multiple redundant Ethernet infrastructures to increase the reliability, availability, and adaptability of critical networks. Moxa's Turbo Chain technology supports flexible multi-ring connections and easy network expansion and is ideal for large-scale redundant networking applications, such as wind power, oil pipelines, and railway applications.

## Moxa Turbo Chain

- **Scenario 1: Wind Power System**

In wind power applications, communication points, such as windmills, are usually scattered throughout the entire wind farm. Redundant Ethernet network connections are an ideal solution to bring windmill nodes together and create a reliable communication network to remotely collect data, control the equipment, and adjust windmill settings. However, making necessary connections often leads to a common problem—that ring redundancy is not able to easily create the entire network in an efficient way. To do so requires a cost-effective yet ultra-flexible topology (refer to the figure below), but typical ring-technologies are too awkward, costly, and inefficient to conveniently link the nodes together. In this case, Turbo Chain is the best solution. It satisfies the application needs for a reliable self-healing network (recovery time < 20 ms) and cost-saving deployment, and remains highly scalable and expandable so that more turbines can be conveniently added in the future.

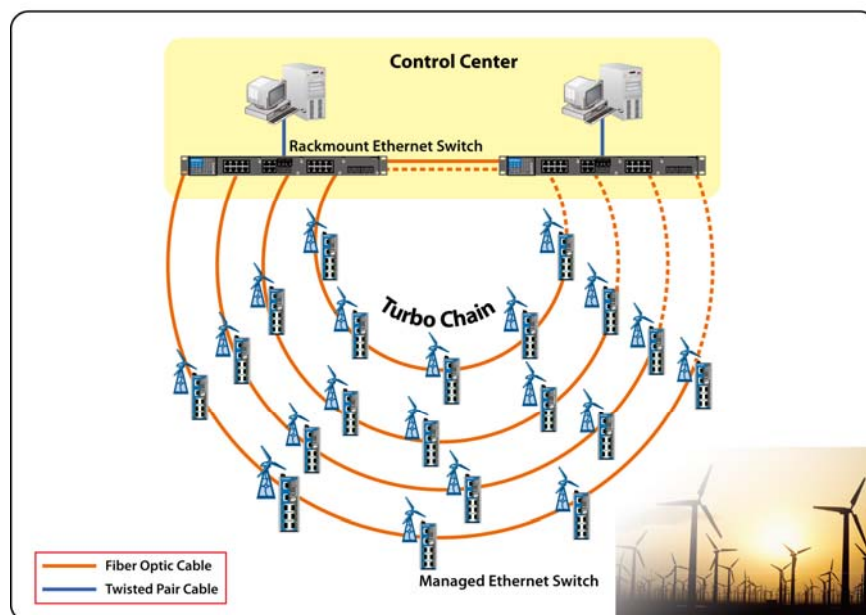

## Moxa Turbo Chain

- **Scenario 2: Oil Pipeline System**

An oil pipeline network spanning many miles normally requires several sub-rings of fiber Ethernet infrastructure at various locations to form a reliable distributed monitoring and control system. However, fiber-cabling expenses of up to tens of thousands of dollars plus days of installation effort need to be expended just to “create and interconnect the sub-rings.” In this scenario, Turbo Chain can be utilized to substantially reduce the deployment expense of the network and enhance system reliability. Independent chains formed in different pipeline network segments can be hooked up to the central redundant ring network rapidly and inexpensively. In this way, the pipeline network can be adaptable and extendable.

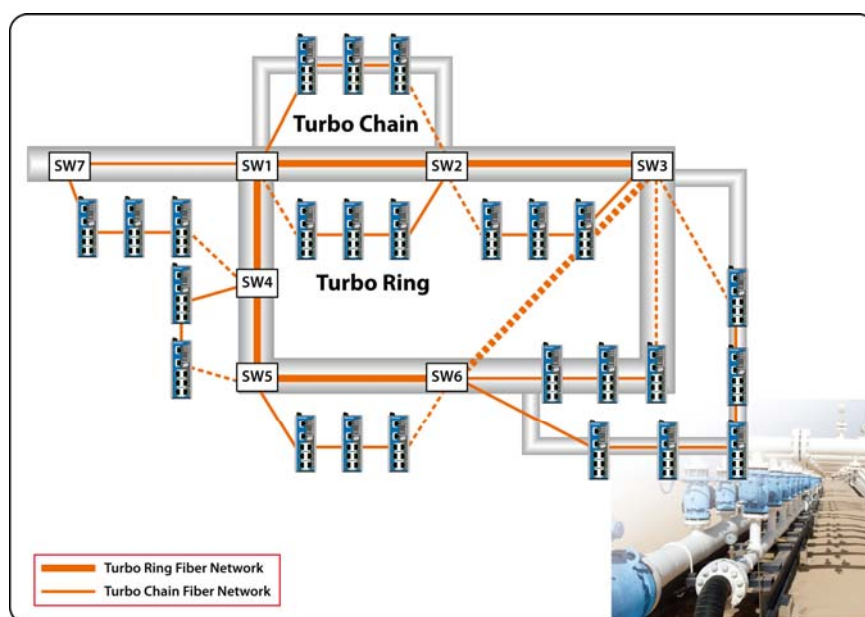

## Moxa Turbo Chain

- **Scenario 3: Railway System**

In a railway system, using a centralized redundant monitoring system to connect different sub-communication stations for real-time operations ensures safe daily transportation. Turbo Chain allows the railway system to scale up easily and quickly whenever the network needs expansion. Instead of creating another sub-ring for the new network, or rerouting/reconfiguring the existing network, administrators can simply chain-up the new nodes, and hook up the chain to the current network. Regardless of whether or not the existing network is running STP, RSTP, or Turbo Ring protocols, Turbo Chain can interoperate with any of them robustly and reliably.

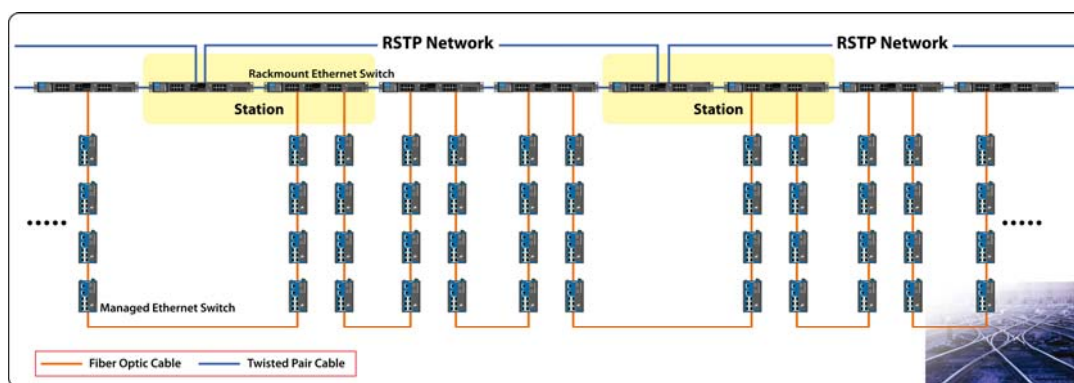

## Moxa Turbo Chain

### Summary

Industrial applications require reliable, redundant network systems to ensure non-stop network operations. Since the complexity of industrial field wiring is growing greater and greater, deploying redundant connections with flexibility and scalability is becoming imperative. Even though there are many existing redundant protocols, Turbo Chain redundant technology, supported by all of Moxa's industrial managed Ethernet switches, is the highest-availability solution that allows network administrators to build multiple redundant connections with the greatest ease and adaptability. The benefits of Turbo Chain redundant technology include:

- Flexible and expandable network construction, with no network reconfiguration effort.
- Complete interoperability with various redundant networks, such as STP, RSTP, and Moxa's Turbo Ring networks.
- Rapid fault recovery (recovery time < 20 ms) of Turbo Chain technology for reliable system operations.
- Cost-effective deployment compared with ring coupling.

**Disclaimer**

*This document is provided for information purposes only, and the contents hereof are subject to change without notice. This document is not warranted to be error-free, nor subject to any other warranties or conditions, whether expressed orally or implied by law, including implied warranties and conditions of merchantability, or fitness for a particular purpose. We specifically disclaim any liability with respect to this document and no contractual obligations are formed either directly or indirectly by this document. This document may not be reproduced or transmitted in any form for any purpose, without our prior written permission.*