

## Moxa White Paper

---

# Site Planning and Wireless Network Installation

*Paul Hsu, Moxa Product Manager*

*paul.hsu@moxa.com*

Building a wireless network can be quite an undertaking. Compared to wired networks, wireless networks require a great deal more planning to install and deploy. In addition to marked differences between wired and wireless LANs, there are currently no standardized procedures for wireless network planning and installation.

So before you begin site planning your network, you need to decide which technologies will be the most beneficial and whether or not consumer-grade products can meet the needs of your mission-critical application. This white paper explains the important factors you should consider in planning and installing a wireless network.

## Why Choose Industrial Wireless?

The convenience of connecting devices without the use of wires has led to the unprecedented success of wireless technologies in the consumer sector. Due to this success, these same technologies are beginning to appear in various other settings including industrial applications. Wireless technologies offer a number of key benefits including mobility, flexibility, wide coverage, and cost savings.

**Mobility and Efficiency:** Improved data communication leads to faster and more efficient transfer of information between people in your organization as well as between you and your customers. Members of your sales team, for example, can

---

Released on August 27, 2008

### Copyright © 2008 Moxa Inc., all rights reserved.

Moxa manufactures one of the world's leading brands of device networking solutions. Products include industrial embedded computers, industrial Ethernet switches, serial device servers, multiport serial boards, embedded device servers, and remote I/O solutions. Our products are key components of many networking applications, including industrial automation, manufacturing, POS, and medical treatment facilities.

### How to contact Moxa

Tel: 1-714-528-6777  
Fax: 1-714-528-6778  
Web: [www.moxa.com](http://www.moxa.com)  
Email: [info@moxa.com](mailto:info@moxa.com)



*This document was produced by the Moxa Technical Writing Center (TWC). Please send your comments or suggestions about this or other Moxa documents to [twc@moxa.com](mailto:twc@moxa.com).*

remotely check stock levels and prices while on a sales call.

**Flexibility and Easy Relocation or Expansion:** In a factory setting, stationary systems can be connected over a wireless network to mobile subsystems or robots to achieve a level of connectivity that would otherwise be impossible. Furthermore, wireless technology can make it much simpler to gain temporary access to plant machinery for diagnostic or programming purposes.

**Wider Coverage:** Because wireless technology allows you to communicate wherever you are, you can send and receive information at any time without being limited by physical wires.

**Saving Time and Money:** Wireless networks can be easier and cheaper to install and implement than wired networks. There is no need to purchase meters and meters of wire or to pay additional installation costs to wire your environment. The average time required to deploy a wireless solution is also significantly shorter than for a wired solution.

However, these advantages also come with additional factors you need to take into consideration when adopting wireless technologies in industrial applications.

**Operating Environment:**

- Wide temperature range
- High humidity and exposure to water, dust, and oil
- Wider and long-distance coverage
- Onsite power supply

**Interface:**

- Heterogeneous communication interfaces
- Management via different data buses and protocols
- Integrated contacts for onsite monitoring and warning

**Reliability and Redundancy:**

- Redundant power supply system
- Redundant media path and looping protection
- Communication switch and fast roaming

**Requirements for Onsite Use:**

- Different installation methods
- Backup and rapid recovery
- Quick status review and diagnosis
- Error prevention

**Better Site Planning**

Site planning and wireless network installation start with the most obvious and simplest questions, such as "What kind of wireless technology do I need?" or "How many wireless access points are needed in this project and where should they be placed?" Planning a wireless network is a trade-off between resources and requests. A well-planned wireless network will reach a balance between technology, system performance, and, of course, installation cost.

Before installing your wireless network, there are some important factors you should consider for your site planning:

**Subjective Factors:**

- Project budget
- Coverage and range
- Data communication rate
- Capacity and location

**Objective Factors:**

- Government regulations
- Technical or environmental limitations
- Radio interference
- Error prevention

We will discuss these factors and considerations in greater detail in the following paragraphs. As you read this section, think about how this information relates to your site planning project.

## What Industrial Wireless Technologies Do I Need?

Different wireless technologies are available to address different application requirements. Some applications require high bandwidth, some require extensive wireless coverage, and some require low power. There are several wireless technologies currently being used in different commercial and industrial applications, as shown in the following landscape map.

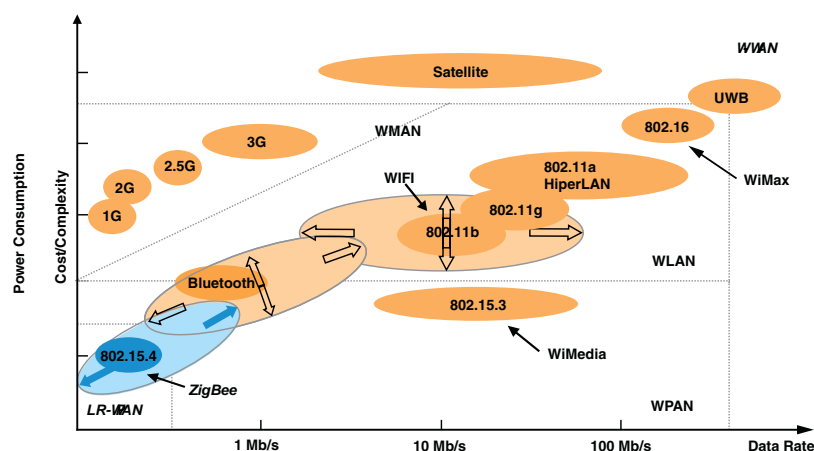

As you can see, these technology options roughly show the relationship between the data communication rate (data rate) and complexity of implementation: the higher the data rate required in the wireless application, the more cost and power consumption it may take. Therefore, you will need to select the most appropriate solution for your wireless network.

The following paragraphs focus more on wireless LAN technology—IEEE802.11 standards—but the information presented here is still relevant to wireless site planning.

### How Much Throughput is Required?

First at all, we need to clarify the difference between data rate and throughput. The data rate is the number of bits that is conveyed or processed per unit of time. It is also called "link rate." The term "data rate" is usually used to describe the theoretical bandwidth of a communication standard or protocol. Since higher data rates require greater transmission

power, a wireless device may offer different Tx power specifications for different data rates.

Throughput is the average rate at which messages (data users really want to send) are delivered over a communication channel. This data may be delivered over a physical or logical link between two specific nodes. The throughput is usually less than the data rate because of additional overhead for network-layer framing and retransmission.

The first question to ask yourself in the planning process should be "How much throughput is required?" You also need to evaluate the expected traffic (average and peak data transmission rate) and unexpected traffic (concurrent peak rate). Then, you can select the suitable wireless technology and data rate. Of course, safety is an important factor in system reliability.

Because bandwidth is described in terms of data rate, not throughput, you should make a practical estimate and expect about 50% of the theoretical data rate. A rough rule of thumb for calculating the network capacity of an IEEE 802.11 access point is shown below.

Technology	Approximate Throughput
802.11b	6 Mbps
802.11g, secured	20-25 Mbps
802.11g, open (rare)	26-28 Mbps
802.11a	26 Mbps

### Where Should We Provide Coverage?

When planning or updating a wireless LAN installation, it is often necessary to determine if your wireless equipment can achieve a certain transmission distance or cover a specific area. However, this information is usually not printed in the specs for wireless devices and antennas. The reason is simple—there are too many factors that affect the transmission distance, particularly the combination of transmission power and antenna gain.

The second major factor is the desired speed. It is easy to provide some wireless LANs access. However, requiring a certain data rate can vary. IEEE 802.11 standards provide various data rates (or rate fallbacks) so the coverage varies as well. The coverage provided at a slower data rate will be much larger than a faster data rate that yields a shorter transmission range. The relationship between distance and data rate is always a trade-off in the three major IEEE 802.11 physical layers.

To simplify the distance calculation, a formula is presented here for calculating the theoretical transmission distance. It is based on the Friis Transmission Equation for free space loss:

$$\frac{P_r}{P_t} = \frac{G_t G_r}{F_L} \left( \frac{\lambda}{4\pi R} \right)^2$$

In this equation,  $R$  is the range and  $\lambda$  is the wavelength. We can take a look at the following figure to see how this corresponds to the specifications of our devices and antennas.

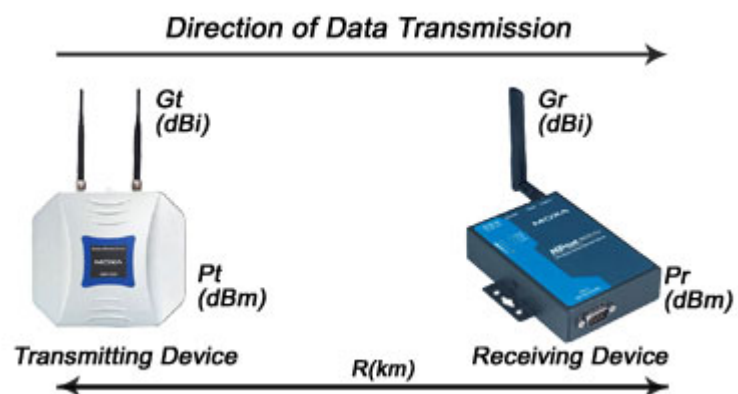

- $P_t$  is the **Tx power** in dBm for the wireless device that will be transmitting data.
- $G_t$  is the **Tx antenna gain** in dBi. This is the gain for the antenna on the device that will be transmitting data.
- $P_r$  is the **Rx sensitivity** in dBm for the wireless device that will be receiving data.
- $G_r$  is the **Rx antenna gain** in dBi. This is the gain for the

antenna on the device that will be receiving data.

- $R$  is the **transmission** distance in km.
- $\lambda$  is the **wavelength** for the wireless signals.
- $F_L$  is a loss factor that adjusts for signal loss in the communication system. It can be used to adjust for signal loss from cable length, impedance mismatching, and other environmental factors.

The Friis Transmission Equation can be modified to suit your needs. What we want is an equation that gives us the transmission distance directly. It is also easier for us to work with communication frequency rather than wavelength. We can modify the Friis Transmission Equation to fit our needs more closely as follows:

$$r = \frac{10^{(p_t + g_t + g_r - p_r)/20}}{41.88 \times f}$$

In this formula,  $f$  is the frequency in MHz. Also,  $P_t$ ,  $P_r$ ,  $G_t$ , and  $G_r$  have been replaced by  $p_t$  and  $p_r$  in dBm and  $g_t$  and  $g_r$  in dBi, which are easier to obtain from product specifications. To get the effective range  $r$  in km, all we need to do is plug in the values for  $p_t$ ,  $p_r$ ,  $g_t$ ,  $g_r$ , and  $f$ .

Since  $r$  is actually the theoretical distance, you should add a safety factor to make the range more realistic. For example, you can divide the theoretical distance of 1.2 km by a safety factor of 1.2 to get a more realistic distance of 1 km that reflects factors such as cable loss and insertion loss.

Of course, there can be a big difference between the theoretical transmission distance and the actual results in the field. These calculations are based on an unobstructed line-of-sight signal with no electronic interference. However, the real world presents many variables that result in less-than-perfect wireless performance, such as mismatched impedance, electronic noise, building obstructions, reflected signals, etc.

This is why it is so important to conduct a thorough site survey in order to determine what is actually happening to your wireless signals in the field. Before you conduct that site survey, however, you still need some way to evaluate the different options you have for wireless hardware. This formula provides a straightforward way to perform that evaluation. With this formula, you can now easily estimate whether you will be able to achieve your desired transmission distance with a given set of hardware. Using this formula, you can make an informed decision when selecting antennas and devices for different wireless applications.

### How to Select and Use an Antenna

The speed of your wireless connection will vary depending on the strength of the signal you can receive and transmit. Antenna selection can therefore have a significant impact on the speed of your wireless link.

There are two basic types of antennas for **WLAN** products categorized by the direction in which they beam radio signals: omnidirectional and directional.

- **Omnidirectional:** Omnidirectional antennas are designed to radiate signals equally in all 360 degrees. Use this type of antenna if you need to transmit from a central node, such as an access point, to users scattered all around the area. In a small office with three or four rooms, an access point with an omnidirectional antenna should be able to provide sufficient coverage for all wireless stations in each room.

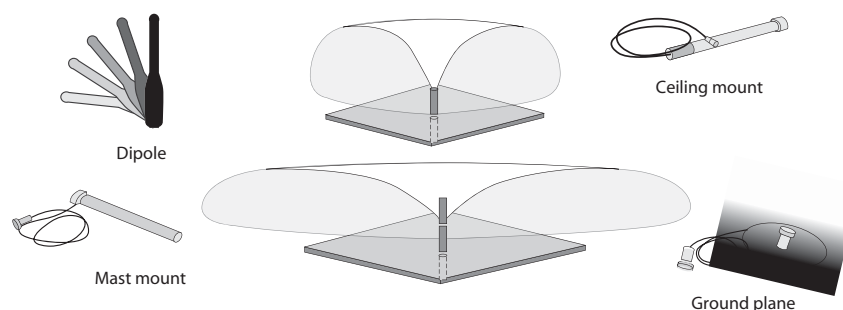

- **Directional:** Directional or patch antennas provide higher

gain and a more focused signal than omnidirectional antennas. Signals are typically transmitted in an oval-shaped pattern with a narrow beam width. This type of antenna is also ideal for indoor locations. For example, an access point with a semidirectional antenna can be placed in one corner of a room to provide reliable coverage for its entire length. Directional antennas can also be used outdoors to provide short distance point-to-point links or as the customer end of a point-to-multipoint network.

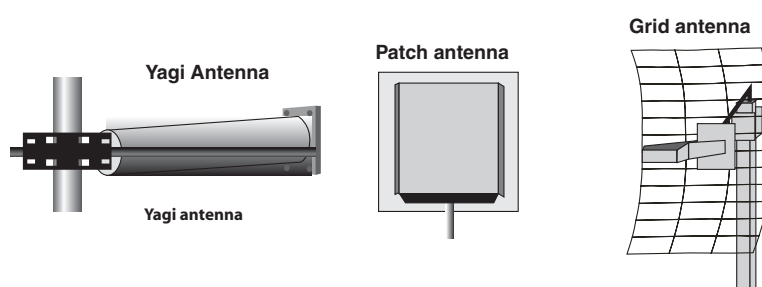

If you are planning to extend the range or widen the coverage, you may need to use external high-gain antennas for your access points. In addition to the antenna type and gain, you need to pay attention to the following specifications:

**Frequency Range:** The most important parameter of an antenna is its working frequency. For example a 2.4G antenna is too weak to use in IEEE 802.11a communication and the data rate will fall back to a very low level. It is unusual to see dual-band or multiple-band antennas, especially for outdoor antennas. Make sure you use the right antenna for your planned working frequency.

**Antenna Polarity:** Polarization refers to the direction electromagnetic waves travel as energy radiates away from the antenna. The simplest and most common example is linear polarization. When power is transmitted from the transmitter to the receiver, only the same polarization portion can be received. As the following figures show, improper antenna installation may have a negative effect on network communication.

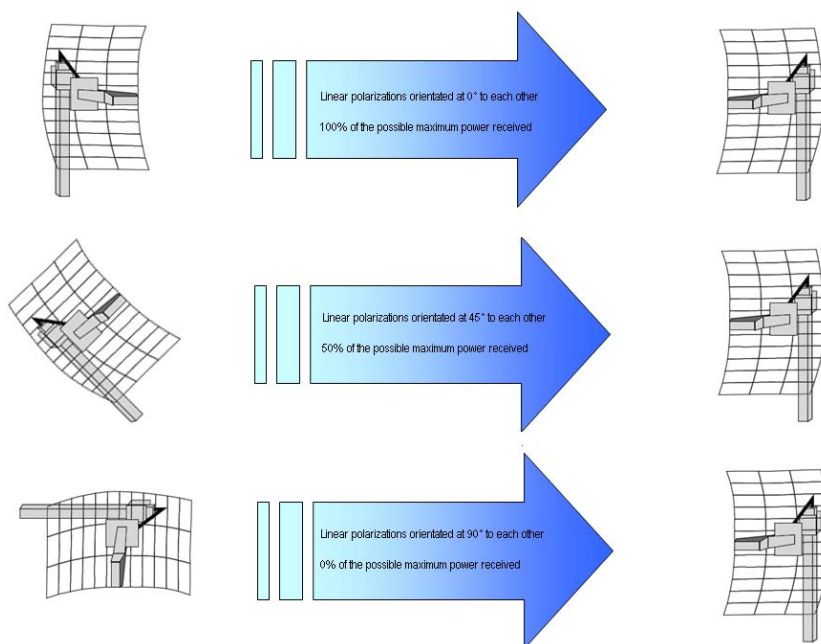

Utilizing antenna polarization can also help make your wireless network more robust. For example, you can install your antennas vertically in an area with mostly horizontal antenna installations, as shown in the following figure, in order to reduce interference.

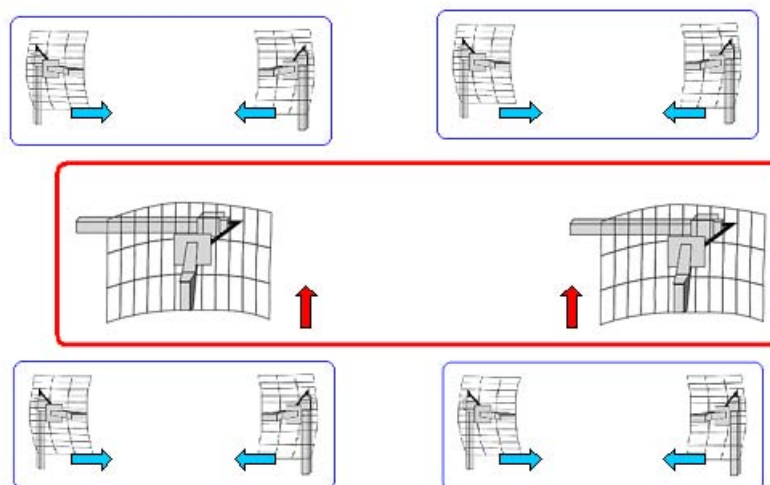

**Half-Power Beam Width (HPBW):** This parameter is measured from the antenna's radiation pattern and refers to the beam width at which the antenna's radiation drops to half of its peak value. It also defines the antenna's effective coverage area. Once you get outside the half-power beam width, the signal typically drops off quite quickly. A very high-gain antenna has a very narrow-angled half-power beam width so the directionality is high as well.

The gain for an antenna is typically measured in dBi and basically indicates how much the signal is boosted by the antenna. Although high gain antennas mean greater transmission distances, they are usually highly directional. Not only does the directional antenna have directionality with a narrow half-power beam width, but a typical omnidirectional antenna also has directionality in the horizontal plane. If the antenna is placed on a tilt, you will find that the signal decreases.

This also means you might experience more difficulty when installing a pair of high-gain antennas. The biggest problem is aiming the antennas at each other properly. Here are some tips to help you:

- You can adjust the direction and aim the antennas by sight if the two sites are visible to each other. The signal strength display can be a good tool when you do the adjustment.
- Otherwise, buy a good compass (or a GPS locator) and a topographical map, and compute the directional angle for the heading from one site to another.
- Here's a trick to help you aim two antennas, A and B, at each other. First, replace antenna B with a high-gain omnidirectional or semidirectional antenna (antenna C). Next, aim antenna A at antenna C. After you reach the maximum signal strength and finish aiming antenna A, replace antenna C with the original antenna B. At the opposite site, aim antenna B at antenna A by substituting antenna A with antenna C at the opposite site.

- If there is a huge difference in height between the antenna sites, you can tilt the higher antenna down and make sure the other one is within the **Inner Cell Radius** and **Outer Cell Radius** coverage areas, as shown in the following figure.

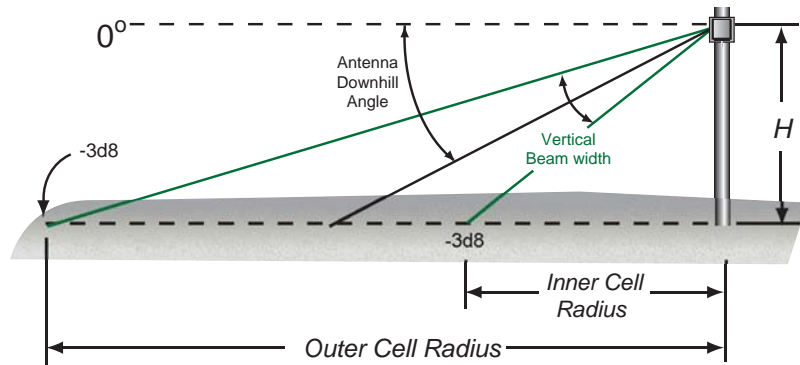

$$\text{Inner Radius Distance} = \frac{H/\tan(A + \frac{BW}{2})}{5280} \quad \text{Outer Radius Distance} = \frac{H/\tan(A - \frac{BW}{2})}{5280}$$

The formulas are:

*Inner Radius Distance = (H/tan(A+(BW/2)))/5280 (Miles);*

*Outer Radius Distance = (H/tan(A-(BW/2)))/5280 (Miles),*

where H is the height difference (in feet);

A is antenna downtilt angle;

BW is the HPBW/Vertical.

- Furthermore, you can also calculate the distance or adjust the angle downwards with the following formulas:

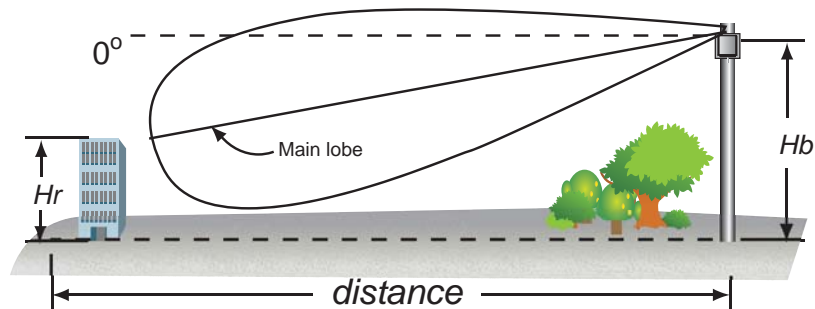

$$\text{distance} = \frac{(Hb-Hr)/\tan A}{5280} \quad \text{angle} = \tan^{-1} \left( \frac{(Hb-Hr)}{\text{distance} \times 5280} \right)$$

- You may consider adding some height compensation if the antennas are installed at different heights. If the antennas are installed over long distances, you may also need to consider the obstacles in between as well as the curvature of the earth (Earth Bulge).

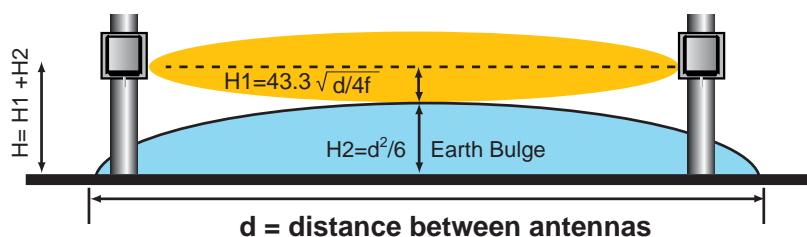

**$H_1$  = Antenna height compensation for Fresnel Zone**

**$H_2$  = Antenna height compensation for Earth Bulge**

Where,

**$d$  is the path length in miles**

and

**$f$  is the frequency in GHz**

$$H = H_1 + H_2$$

### **$H_1$ : The Fresnel Zone**

In addition to a clear line of sight for maintaining signal strength, the area (Fresnel Zone) around the visual line-of-sight, which radio waves spread into after they leave the antenna, should be clear as well. Typically, 20% Fresnel Zone blockage introduces little signal loss to the link. Beyond 40% blockage, signal loss will become significant.

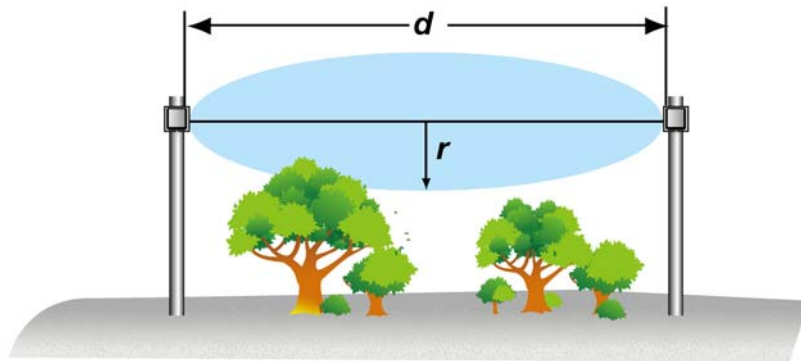

$$r \text{ (in mts)} = 17.32X \sqrt{\frac{d \text{ (in km)}}{4f \text{ (in GHz)}}$$

$$r \text{ (in ft)} = 72.05X \sqrt{\frac{d \text{ (in km)}}{4f \text{ (in GHz)}}$$

### **H2: Compensating for Earth Bulge**

The previous calculation is based on a flat earth. It does not take the curvature of the earth into consideration and leads to distortion. It is recommended for long links to have a microwave path analysis done that takes this and the topography of the terrain into account. The simple formula for determining Earth Bulge is  $d^2/6$ , where  $d$  is the distance in miles.

### **Choosing the Right Level of WLAN Security**

The right balance between security, transparency, and cost effectiveness is important when determining the type of security to use for your WLAN. You should take into account your target environment, the security levels that your WLAN can support, and potential performance effects from stronger security methods. Here are a few key questions that can help you evaluate your security options:

- Does your environment require a high level of security? If the WLAN will be used to send and receive sensitive information, such as financial data, you would likely want the highest level of security available. On the other hand, if the WLAN will only be used to send and receive raw data from factory equipment, a lower level of security may be preferable in order to optimize wireless performance.

- What level of security can your network environment support? WPA and WPA2 encryption technologies offer reliable security for a range of needs, but can all your clients support them? If you plan to implement 802.1X authentication, do you have a RADIUS server available on the network?
- Will a high level of security cause an unacceptable drop in wireless performance? How will the performance of your wireless devices on the network be affected if you enable encryption? Encryption can be a significant additional processing load, since devices must encrypt outgoing data and decrypt incoming data. Can your devices, including your device servers, handle this additional load?

The following table summarizes the implementation considerations and client requirements for the main WLAN security methods.

Method	Client Support	Considerations
WEP	Built-in support on all 802.11a, 802.11b, and 802.11g devices	<ul style="list-style-type: none"> <li>• Provides weak security.</li> <li>• Requires manual key management.</li> </ul>
WPA	Requires WPA-enabled system and network card driver	<ul style="list-style-type: none"> <li>• Provides dynamically generated keys that are periodically refreshed.</li> <li>• Provides similar shared key user authentication.</li> <li>• Provides robust security for small networks.</li> </ul>
WPA2	Requires WPA-enabled system and network card driver	<ul style="list-style-type: none"> <li>• Provides robust security for small networks.</li> <li>• Requires manual management of pre-shared key.</li> <li>• Wireless stations may require hardware upgrade to be WPA2-compliant.</li> </ul>
802.1X	Requires WPA-enabled system and network card driver	<ul style="list-style-type: none"> <li>• Provides dynamically generated keys that are periodically refreshed.</li> <li>• Requires configured RADIUS server.</li> <li>• Provides backward compatibility with the original WPA.</li> </ul>

## Site Survey Tools

A number of WLAN vendors provide free RF site survey software that can help you determine the effective data rate, signal strength, and signal quality at your site when an access point is installed at a particular location. You can install this software on a laptop and use it to test the effectiveness of potential access point locations.

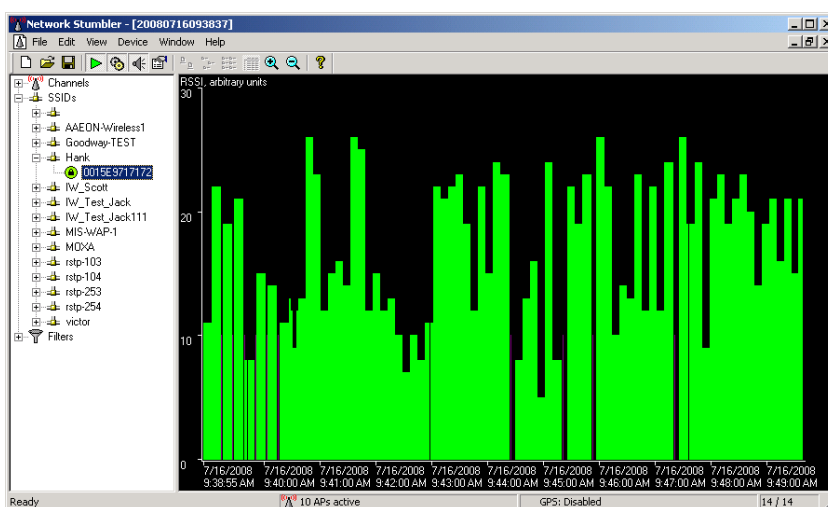

You can download this utility from Network Stumbler ([www.netstumbler.com](http://www.netstumbler.com)). The following general steps should be followed when performing a site survey. Remember, the objective of the survey is to identify potential sources of interference in the target environment and determine the best locations for your access points.

1. Familiarize yourself with the target environment and check for physical barriers that may affect the propagation of wireless signals. A list of materials that can affect or block wireless signals is provided in the next section.
2. Identify user areas, including fixed areas (such as desks) and roaming areas where users may temporarily require wireless connectivity (such as meeting rooms).
3. Based on the information you have obtained on the site's physical barriers and user areas, identify potential locations

for access points. Ideally, access points should be centrally located to the wireless clients.

4. Install an access point at each preliminary location and use a site survey tool to check the data rate and signal strength at different points. Use a signal strength indicator to determine the outer bounds of coverage for each access point. To ensure good reception throughout the site, access points need to be spaced close enough to each other so that their outer bounds of coverage overlap. However, you must also make sure that they are spaced far enough from each other so interference is minimized. Use the site survey tool to identify sources of interference. You may need to place your access points in different locations and re-test the data rates and signal strength. If you have identified a significant number of sources of interference, you may need to perform a more detailed site survey. If these sources of interference cannot be eliminated, you will likely need to deploy more access points to compensate for the signal loss.
5. Finally, deploy the access points. If you are deploying multiple access points, Moxa recommends configuring each one for a different wireless channel. This will help resolve any interference issues and improve the wireless signal.

### **Building Your Industrial Wireless Network**

In addition to fundamental knowledge of wireless LAN technologies, a planner needs to be informed about various demands for industrial-grade applications and consider the following issues:

#### **Critical Operating Environment**

- Wide operating temperature range
- IP-rated (where IP stands for ingress protection) housing for water, oil, and dust
- Wide-range or long-distance communication support
- Onsite power source

**Interface Collaboration**

- Support for different data communication interfaces
- Device management via field buses or industrial Ethernet
- Integration of digital inputs and outputs for detection and warning

**High Reliability and Redundancy**

- Support for several redundant power inputs
- Redundant path and looping protection
- Fast connection switching and roaming

**Easy Administration and On-field Maintenance**

- Support for various types of mounting
- Rapid system recovery
- Quick system status review and error detection
- Error prevention

**Conclusion**

Wireless networks have become a major trend in industrial applications due to the convenience of connecting remote devices without the use of wire conduits. More importantly, wireless technologies offer a number of key benefits including flexible deployment, cost-effectiveness, greater versatility for expansion or migration, and wider network coverage.

There are many industrial wireless technologies and solutions, including proprietary or standardized WPAN, WLAN (IEEE 802.11), and WWAN (GSM, GPRS, HSDPA, WCDMA, etc.), to serve a broad spectrum of industries. The wireless planner should take a holistic view in his application and carefully choose from a wide selection of industrial wireless solutions.

In addition to knowledge of wireless technologies and industry demands, onsite observation and testing can provide helpful information for decision-making, troubleshooting, and verification of selected wireless solutions.

**Disclaimer**

*This document is provided for information purposes only, and the contents hereof are subject to change without notice. This document is not warranted to be error-free, nor subject to any other warranties or conditions, whether expressed orally or implied by law, including implied warranties and conditions of merchantability, or fitness for a particular purpose. We specifically disclaim any liability with respect to this document and no contractual obligations are formed either directly or indirectly by this document. This document may not be reproduced or transmitted in any form for any purpose, without our prior written permission.*